

P/N

SR-EI1002

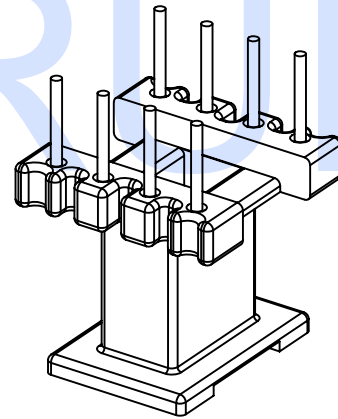
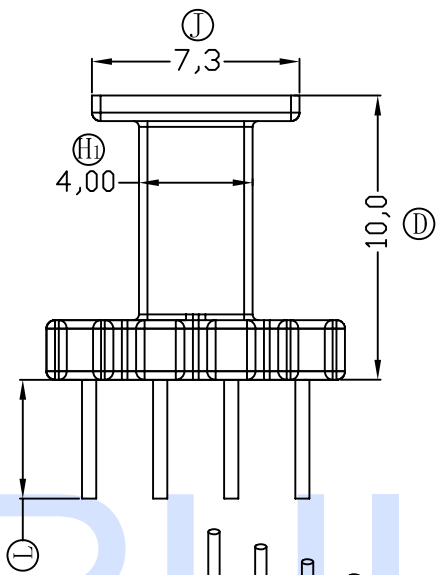
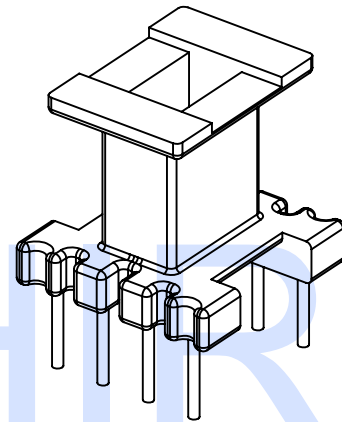
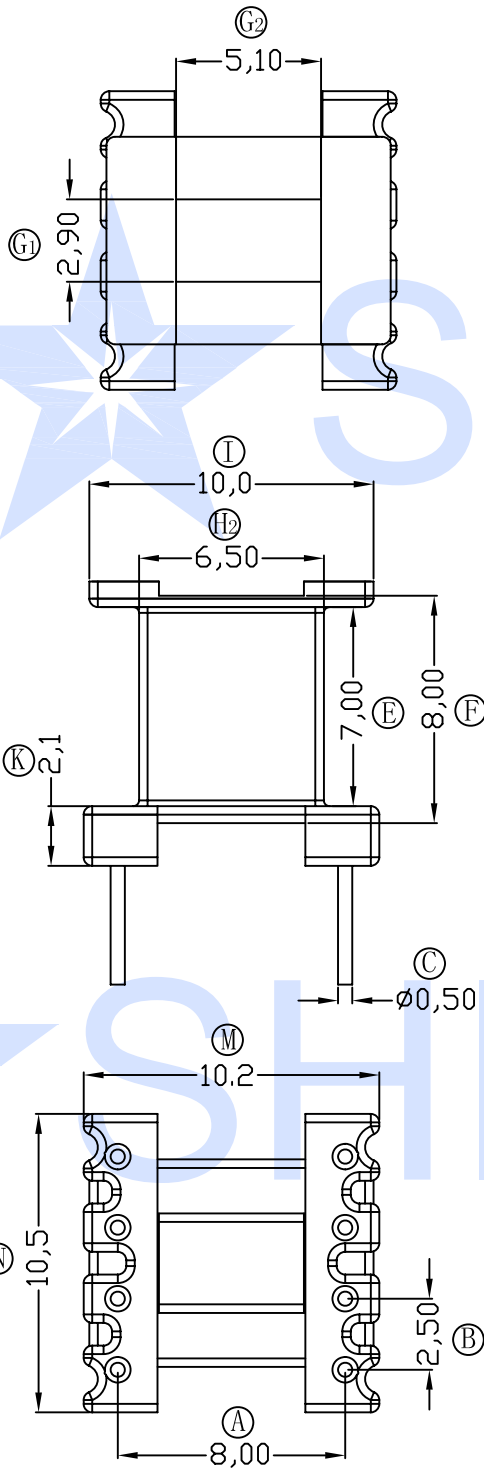

Anhui Shirui Electronic Technology Co., Ltd

TEL: (0086) 55165232650

sales@shiruitech.com

www.shiruitech.com

SR NO. SR-EI1002	MATERIAL: PHENOLIC	UNIT: mm	TOLERANCE	DRN.	WILL H
MODEL NAME! EI10-8P-1S V	UL REC: UL 94V-0		0 L 4 ± 0.10	CHD.	IRINA LEE
	ANGLE: \pm°		4 L 16 ± 0.20	ISSD.	JAMES HU
			16 L 64 ± 0.30		
			PIN PITCH ± 0.05		

Contact salesman:sales@shiruitech.com,For technique to contact :james@shiruitech.com